

OptiView™ Link Analyzer

OPV-LA and OPV-LA/HD

Users Manual

P/N 750003-04 Rev.B

June 2003

© 2001, 2002, 2003 Fluke Networks. All rights reserved. Printed in USA
All product names are trademarks of their respective companies.

LIMITED WARRANTY AND LIMITATION OF LIABILITY

Fluke Networks warrants its products to be free from defects in material and workmanship under normal use and service for one (1) year, beginning on the date of shipment. This warranty extends only to the original buyer or end-user customer of a Fluke Networks authorized reseller, and does not apply to fuses, disposable batteries, or to any product which, in Fluke Network's opinion, has been misused, altered, neglected, contaminated, or damaged by accident or abnormal conditions of operation or handling. Fluke Networks warrants that software will operate substantially in accordance with its functional specifications for 90 days and that it has been properly recorded on non-defective media. Fluke Networks does not warrant that software will be error free or operate without interruption.

Fluke Networks authorized resellers shall extend this warranty on new and unused products to end-user customers only but have no authority to extend a greater or different warranty on behalf of Fluke Networks.

Fluke Networks' warranty obligation is limited, at Fluke Networks' option, to refund of the purchase price, free of charge repair, or replacement of a defective product which is returned to a Fluke Networks authorized service center within the warranty period.

To obtain warranty service, call Fluke Networks for instructions. Following warranty repair, the product will be returned to Buyer, transportation prepaid (FOB Destination). If Fluke Networks determines that failure was caused by neglect, misuse, contamination, alteration, accident, or abnormal condition of operation or handling, including over-voltage failures caused by use outside the product's specified rating, or normal wear and tear of mechanical components, Fluke Networks will provide an estimate of repair costs and obtain authorization before commencing the work. Following repair, the product will be returned to the Buyer transportation prepaid and the Buyer will be billed for the repair and return transportation charges (FOB Shipping Point).

Warranty service is available outside the United States only if product was purchased through a Fluke Networks Authorized Sales outlet in the country of use or the applicable Fluke Networks international price was paid. Product transported from the United States for which the applicable Fluke Networks International price was not paid must be returned to the U.S. to receive warranty service, at the shipment expense and risk of Buyer. Fluke Networks reserves the right to invoice Buyer for importation costs of repair/replacement parts when product purchased in one country is submitted for repair in another country.

THIS WARRANTY IS BUYER'S SOLE AND EXCLUSIVE REMEDY AND IS IN LIEU OF ALL OTHER WARRANTIES, EXPRESS OR IMPLIED, INCLUDING BUT NOT LIMITED TO ANY IMPLIED WARRANTY OF MERCHANTABILITY OR FITNESS FOR A PARTICULAR PURPOSE. FLUKE NETWORKS SHALL NOT BE LIABLE FOR ANY SPECIAL, INDIRECT, INCIDENTAL, OR CONSEQUENTIAL DAMAGES OR LOSSES, INCLUDING LOSS OF DATA, ARISING FROM ANY CAUSE OR THEORY.

Since some countries or states do not allow limitation of the term of an implied warranty, or exclusion or limitation of incidental or consequential damages, the limitations and exclusions of this warranty may not apply to every buyer. If any provision of this Warranty is held invalid or unenforceable by a court or other decision-maker of competent jurisdiction, such holding will not affect the validity or enforceability of any other provision.

Fluke Networks
P.O. Box 9090
Everett, WA 98206-9090
U.S.A.

Fluke Europe B.V.
P.O. Box 1186
5602 BD Eindhoven
The Netherlands
11/99

Note:

Contact Fluke Networks Sales, Service, and Support Centers

To locate the nearest Fluke Networks distributor or Service Center, visit us on the World Wide Web at www.flukenetworks.com or email to info@flukenetworks.com or call:

USA: 1-800-283-5853

Anywhere in the world: +1-425-446-4519

Europe: +31 40-267-8300

Japan: +81-3-3434-0188

Singapore: +65-737-2922

Table of Contents

Title	Page
Introduction	1
OPV-LA/HD Model for Capture to Disk.....	2
Installing the OPV-LA	3
Installation Overview.....	3
OPV-LA LEDs.....	6
Setting the OPV-LA IP Address	7
Administration of OPV-LA over the Internet	9
Updating OPV-LA System Image	9
Updating OPV-LA System Image Using Telnet.....	11
Connecting to the Network	12
Connecting to Half-Duplex Links or Mirror Ports.....	12
Connecting to Multiple Segments through a 12-Port Tap.....	13
Connecting to a 1000Mbps Link through a Fiber Tap.....	14
Connecting to Multiple 1000Mbps Segments through a Multi-Port Tap or Access Switch	16
OPV-LA System Operation Commands	18
module captureSlice.....	18
module currentSettings.....	19
module direction.....	20
module getSpeed.....	20
module monitorSlice.....	20
module rxCounters.....	21
module rxOption.....	21
module setInterface.....	22
module startRx.....	22

module stopRx	22
OPV-LA Setup Commands	23
Set, Get, and Del Commands	23
Ping Command.....	24
Using Help	24
Setting the System Time and Date	24
OPV-LA Setup Command Variables	27
connectingClients	27
date	27
disconnectClient.....	27
email.....	28
imageProperties.....	29
ipAddr	29
ipDefGw.....	29
ipServerAddr	30
ipSettings.....	30
ipSubnetMask.....	30
ldBootFile.....	31
ldBootMode.....	32
ldLoadMode	33
ntpAutoUpdate	33
ntpMinFromUTC	34
ntpServerAddr	34
ntpSettings.....	34
ntpTimeoutValue.....	35
ntpUpdate	35
ntpUpdateInterval.....	36
snmpComm	36
sysBootSwVersion	37
sysHwBoardId.....	38
sysHwMacAddr.....	38
sysHwReset	38
sysHwVersion	38
sysMgmtPortSpeed	39
sysResetType.....	39
sysSwVersion.....	39
systemInfo	40
sysUpTime	41
tapRescan	41
telAccess	41
telTimeout	42
time.....	42
usrTable.....	43
wdtimer	44
OPV-LA and OPV-LA/HD Specifications	45
Physical Specifications.....	45
Environmental Specifications	45
Power Specifications.....	45
Port Specifications	46
Operational Specifications	46

List of Tables

Table	Title	Page
Table 1.	OPV-LA LEDs	6
Table 2.	OPV-LA System Operation Commands.....	18
Table 3.	User Interface Commands and Variables	25
Table 4.	Default User Names, Passwords, and Privileges	43

List of Figures

Figure	Title	Page
Figure 1.	OPV-LA Ports	4
Figure 2.	OPV-LA LEDs	7
Figure 3.	OPV-LA System Half-Duplex and Single Mirror Port Connections	12
Figure 4.	OPV-LA to Tap-12 Configuration	13
Figure 5.	OPV-LA to Fiber Tap Configuration	15
Figure 6.	OPV-LA System to FTAP-8M or FTAP-8S Multi-Port Tap Configuration	16

OptiView™ Link Analyzer

Introduction

The Fluke Networks OptiView™ Link Analyzer (OPV-LA or OPV-LA/HD) is a troubleshooting and monitoring system designed for use by field service and network operations personnel for monitoring 10/100/1000Mbps Ethernet networks. The OptiView™ Link Analyzer can be rack-mounted at your data center, strategically located anywhere in your network, or used in conjunction with a laptop PC as a portable troubleshooting system.

Accessed locally or remotely by Fluke Networks OptiView™ Protocol Expert software, the OptiView™ Link Analyzer provides the tools necessary to effectively diagnose, troubleshoot and monitor any full or half-duplex 10/100/1000 Ethernet network.

The OptiView™ Link Analyzer ensures that every packet on a network segment is captured, including error packets. Both simultaneously perform monitoring and troubleshooting functions at full line rate.

The OptiView™ Link Analyzer chassis contains two Integrated Media Module (IMM) cards. The OptiView™ Link Analyzer is only available in a dual interface configuration. This dual-interface configuration allows the unit to monitor traffic on one full-duplex Ethernet switch link, two half-duplex segments, or two mirror ports.

The analyzer ports connect to the network through an auto-sensing 10/100 Mbps RJ-45 port with a built-in transceiver or 1000Mbps G-BIC connectors for SC-terminated multi-mode fiber optic cabling. 1000BASE-LX networks are supported with optional Single mode 1000BASE-LX G-BIC connectors

The 10/100 Mbps Ethernet management port provides a connection to the 10/100 Mbps network or a direct connection to a PC's 10/100 Mbps Ethernet adapter. Connected to any 10/100 Mbps Ethernet port, the OptiView™ Link Analyzer becomes accessible to any OptiView™ Protocol Expert software on the network. Once the OptiView™ Link Analyzer IP address is established through the console port, other configuration can be performed through the management port over the Internet.

The OptiView™ Link Analyzer has two 9-pin serial ports. Serial ports can be used for configuring local IP addresses, connecting to a Fluke Networks Multi-port Tap, or for updating the OptiView™ Link Analyzer software. Configuration is performed using a command-line interface. Configuration commands are passed to the OPV-LA by connecting one of the 9-pin serial ports to a terminal or to a PC with a terminal emulation program.

The OptiView™ Link Analyzer can collect information from any 10/100 Mbps segment directly connected to a Fluke Networks Single Port Tap (Tap-1) or Fluke Networks 12-port Tap (Tap-12). The Fluke Networks Tap-12 provides a switching mechanism for monitoring any one of 12 full or half-duplex segments. Refer to the section “Connecting to the Network” for complete information on how to make connections between the OptiView™ Link Analyzer and a Fluke Networks Tap-12.

The OptiView™ Link Analyzer can collect information from any 1000Mbps segment directly connected to a Fluke Networks Fiber-Tap (single port or 8 port). The Fiber-Tap enables the user to monitor both receiving sides of a full-duplex segment. Monitoring of multiple 1000 Mbps segments is supported through either a connection to a Fluke Networks 8 port Fiber-Tap or a third party 1000 Mbps fiber-optic switch. Refer to the section “Connecting to the Network” for complete information on how to use Fluke Networks Fiber-Tap with the OptiView™ Link Analyzer.

OPV-LA/HD Model for Capture to Disk

The OPV-LA/HD Distributed Monitoring and Analysis System adds a 80 Gigabyte IDE hard drive to the features of the OPV-LA. The internal disk in the analyzer device allows you to stream extended network information to disk.

The OPV-LA/HD is externally identical to the OPV-LA model described above—it has the same analyzer ports, management port, serial ports, and LEDs. Set the mode to capture-to-disk for the OPV-LA/HD from OPV-PE, from the Web Console software over the Internet, or by the local **module RxOption** command. There are no other settings or formatting required to set up capture to disk. A capture stored on the OPV-LA/HD disk can be downloaded in segments for viewing and decoding in OptiView™ Protocol Expert and can be saved to a file on a PC.

All further references to OPV-LA in this document apply to both the OPV-LA and OPV-LA/HD models except where noted.

Installing the OPV-LA

The OptiView™ Link Analyzer features a command-line interface that is accessible from any VT-100 terminal or from any PC or laptop running VT-100 terminal-emulation software. This portability and accessibility provide you with unlimited installation flexibility. You can transport your OPV-LA to any network location or rack mount it at your network control center.

Installation Overview

1. Inspect the packaging and its contents for visible damage. If you notice any damage, please contact Fluke Networks immediately.
2. When you receive your OptiView™ Link Analyzer, the package will contain the following items:
 - OPV-LA System
 - *OptiView™ Link Analyzer- Users Manual* (this manual)
 - 100-120 V Power Cord (U.S. only)
 - Serial Cable Set
 - 9-Pin Female to 9-Pin Male Cable, 2.9 Meters
 - 9-Pin Male to Female Converter
 - 9-Pin Male to 25-Pin Male Converter
 - Cross-over RJ-45 Cable
 - Rack Mounting Kit

Please check the contents of the package to make certain you have received all the components in the above list. If any items are missing, please contact Fluke Networks immediately.

3. Place your OPV-LA in a location where you have ready access to the following:
 - Physical connection to your local area network
 - 110-120V, surge-protected, power source
 - VT-100 terminal, or a desktop or portable computer that is running VT 100 terminal emulation software.

If you want to rack mount the OPV-LA; follow the instructions that accompany the rack-mount tray. With the tray securely attached, mount the OPV-LA in your equipment rack.

4. Plug in the OPV-LA. Attach the female end of the power cord to the OPV-LA power receptacle on the left rear side of the unit and the male end into an appropriate power source.
5. Use the 9-pin cable and necessary cable converters to connect the OPV-LA to either a VT-100 terminal or a desktop or laptop computer running VT-100 terminal emulation software. Plug one end of the cable into the Console port (9-pin port on the left, see Figures 1 and 2), and the other end into a COM port on your computer or the serial port on your computer.

Figure 1 shows the right side of an OPV-LA unit.

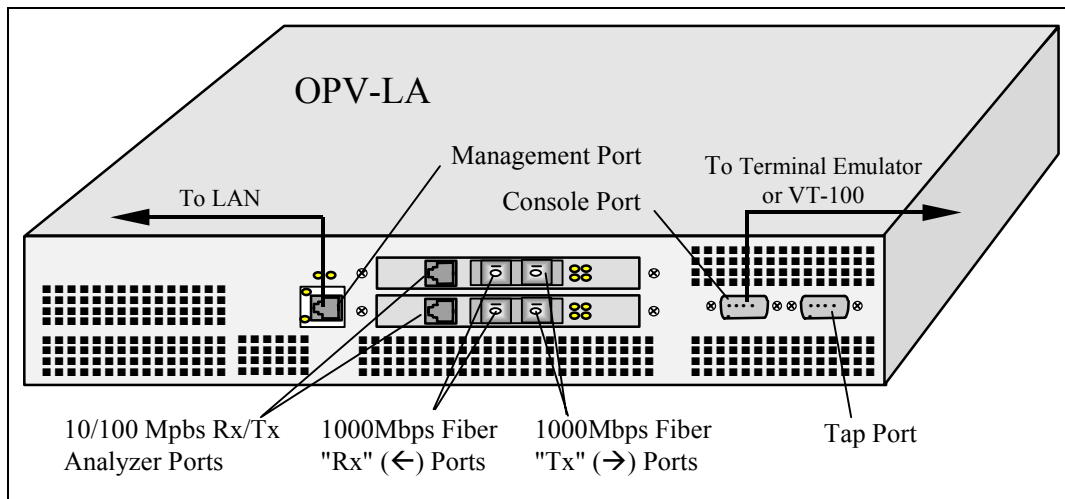

Figure 1. OPV-LA Ports

6. Connect the management port to your network using an RJ-45 straight cable (not the cross-over cable supplied).
7. Configure the OptiView™ Link Analyzer for network operations. See “Setting the OPV-LA IP Address” for instructions.

8. Connect the analyzer ports to your network.

For the OPV-LA 10/100 Mbps connection:

Use the RJ-45 port for each IMM card. To see full line rate traffic in both directions, connect both analyzer ports through a device such as a Fluke Networks Tap or Fluke Networks Multi-port Tap.

For OPV-LA 1000Mbps direct connection:

Connect the "Rx" (←) and "Tx" (→) ports for each IMM card to the switch. To see full line rate traffic in both directions, connect both "Rx" (←) analyzer ports through a device such as a Fiber Tap.

For an OPV-LA Using a Fiber Tap:

For passive bi-directional monitoring, connect only the "Rx" (←) port for each IMM card.

The OptiView™ Link Analyzer can be connected to the network in a variety of ways. See “Connecting to the Network” for 10/100 Mbps and gigabit Ethernet network connection instructions and examples.

OPV-LA LEDs

The LEDs can be found on the right side of the unit.

Table 1. OPV-LA LEDs

POWER	Indicates if power to the OPV-LA system is ON or OFF. The power-plug receptacle is on the back of the unit.
STATUS	Indicates the status of the OPV-LA system. If the status LED is blinking, the CPU is active and functional. If the LED does not blink, the CPU is not running and there is a problem with the state of the OPV-LA device.
10 OFF / 100 ON (Management Port Speed)	Indicates the speed of the Management Port. If the LED is OFF, port speed is 10 Mbps; if LED is ON port speed is 100 Mbps.
LINK (Management Port Link)	If the LED is ON, the 10/100 Mbps link for the management port is active. If it is OFF, there is no link. This LED indicates that the management port is detecting a signal..
10/100 (10/100 Mbps Analyzer Port Select)	LED under software control for the IMM card. If the LED is ON, the 10/100 Mbps port is selected. If it is OFF, the port is not selected. A blinking LED identifies the physical card so users can match the physical device with a logical name.
LINK (10/100 Mbps Analyzer Link Active)	If the LED is ON, the 10/100 Mbps link for this IMM card is active. If it is OFF, there is no link. This LED indicates that the 10/100 Mbps RJ-45 port is detecting a signal.
GIG (Gigabit Analyzer Port Select)	LED under software control for the IMM card. If the LED is ON, the 1000 Mbps send/receive ports are selected. If it is OFF, these ports are not selected. A blinking LED identifies the physical card so users can match the physical device with a logical name.
LINK (Gigabit Link Active)	If the LED is ON, the 1000 Mbps link for this IMM card is active. If it is OFF, there is no link. This LED indicates that the MAU is detecting a signal on the incoming optical cable attached to the MAU receive port.

There are two IMM cards per OPV-LA, therefore two sets of four analyzer card LEDs.

The location of LEDs is shown in the diagram below:

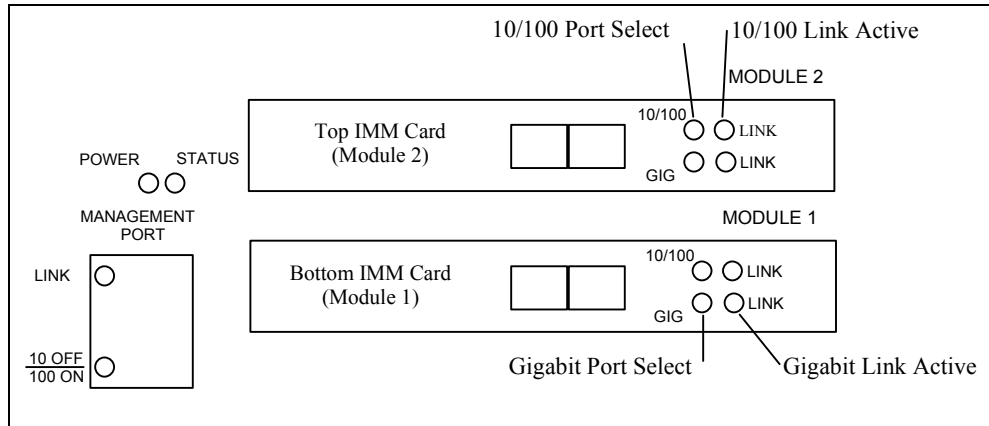

Figure 2. OPV-LA LEDs

Setting the OPV-LA IP Address

You must set the IP address of the OptiView™ Link Analyzer so that it can be located on the network and mapped into OptiView™ Protocol Expert software. In most environments, you will also need to set the subnet mask and the default gateway address for the OPV-LA.

1. If you are using a PC, start your terminal emulation software program on the PC.
2. Configure the terminal or terminal emulation software to communicate with the OPV-LA. The terminal device must be connected to the serial port with the following settings:
 - 9600 Baud, 8 Data Bits, 1 Stop Bit, No Parity
 - No hardware/software flow control

3. Verify that you are connected to the OPV-LA. From the command prompt, type:

```
>get ipAddr
```

The OPV-LA should return the following IP address:

```
0.0.0.0
```

All zeros is the default IP address setting.

4. Set the OPV-LA IP address as follows:

```
>set ipAddr a.b.c.d
```

Where a.b.c.d is the address you want to assign to the OPV-LA in dotted notation.

5. Set the subnet mask for the OPV-LA as follows:

```
>set ipSubnetMask a.b.c.d
```

Where a.b.c.d is the subnet mask of the OPV-LA in dotted notation.

6. Set the gateway address for the server as follows:

```
>set ipDefGw a.b.c.d
```

Where a.b.c.d is the default gateway IP address for the OPV-LA in dotted notation.

7. Reset the OPV-LA:

```
>set sysHwReset Warm
```

Note

You must issue the set sysHwReset Warm command for the OptiView™ Link Analyzer to use the new addresses. Cycling power on the unit will not set addresses. Refer to the following section to perform a software update. Refer to the section “OPV-LA Setup Commands” for complete information on all commands.

Administration of OPV-LA over the Internet

After you set the IP address of OPV-LA, you can perform other administration and configuration activities over the Internet. To log into the OPV-LA system, use the IP address as the URL. For example, if the IP address of the OPV-LA is 137.24.233.6:

`http://137.24.233.6.`

When you reach the OPV-LA, you'll be asked for a username and password. These are the same usernames and passwords set up using the `usrTable` variable as described on page 40.

You can use the default accounts and passwords to log in. OPV-LA has two factory-supplied accounts, as follows:

User Name:	Password:	Privileges:
guest	public	full
su	manager	super

To provide system security, you should change the default accounts. Accounts and passwords can be changed once you are logged in with "super" privileges.

Updating OPV-LA System Image

This procedure is only for updating the OptiView™ Link Analyzer system image when new versions become available. The current version of OPV-LA system image can be found in the OptiView™ Protocol Expert software CD under the "Hardware Image File" directory. There is no need to run this procedure when you first install the OptiView™ Link Analyzer. You can use either of the following procedures to update the software in the OPV-LA, or you can update your remote OPV-LA directly from the OptiView™ Protocol Expert software via the **Reset Host** window. This window can be opened from the drop down menu item **Host > Properties** and pressing the **Reset Host \ Image Upgrade** button. You must first connect to the remote OPV-LA with Super User privileges and your image files must be loaded on a accessible TFTP server before this feature will work. Refer to your OptiView™ Protocol Expert documentation for more information.

You must have the Ethernet port on the OPV-LA connected to the network to perform an update of the system image using either of the procedures below.

Updating OPV-LA Using Terminal Emulation

1. Place the software on the server that runs TFTP protocol.
2. If you are using a PC, start your terminal emulation software program on the PC.
3. Configure the terminal or terminal emulation software to communicate with the OPV-LA. Use the following serial port settings:
 - 9600 Baud, 8 Data Bits, 1 Stop Bit, No Parity
 - No hardware/software flow control

4. Verify that you are connected to the OPV-LA. From the command prompt, type:

```
>get ipAddr
```

The OPV-LA should return the IP address of the OPV-LA.

5. Set the IP address of a server that runs BOOTP and/or TFTP protocols. The BOOTP protocol is used to pass address information, while the TFTP protocol is used to transfer a new version of the software.

```
>set ipServerAddr a.b.c.d
```

Where a.b.c.d is the IP address of the server in dotted notation.

6. Set the path name to the software image file. For example:

```
>set ldBootFile c:\tftp\dp50b057.img
```

Where c:\tftp\dp50b057.img is the full pathname of the image file on the server.

7. Set the load mode for the OPV-LA to `Network`. For example:

```
>set ldLoadMode network
```

Updating OPV-LA System Image Using Telnet

1. Place the new systems image on the server that runs TFTP protocol.
2. Run Telnet from your PC.
3. Select `Connect` from the Telnet screen.
4. Enter the IP address of your OptiView™ Link Analyzer in dotted notation for the host name. Use `VT100` as the terminal emulation type.
5. At the `Username :` prompt, enter `su`. The default password is `manager`.
6. Set the IP address of a server that runs BOOTP and/or TFTP protocols. The BOOTP protocol is used to pass address information, while the TFTP protocol is used to transfer a new version of the software.

```
>set ipServerAddr a.b.c.d
```

Where `a.b.c.d` is the IP address of the server in dotted notation.

7. Set the path name to the software image file. For example:

```
>set ldBootFile c:\tftp\dp50b057.img
```

Where `c:\tftp\dp50b057.img` is the full pathname of the image file on the server.

8. Set the load mode for the OPV-LA to `Network`. For example:

```
>set ldLoadMode network
```

Connecting to the Network

The following subsections show typical ways to connect the OptiView™ Link Analyzer to an Ethernet network.

Connecting to Half-Duplex Links or Mirror Ports

The OptiView™ Link Analyzer can be connected to half-duplex links or single mirror ports. Each IMM card in the OPV-LA can be connected to a 10/100 Mbps and a 1000Mbps link, but only one connection is selected at a time. In the example below, the top IMM card is connected to Device B through its RJ-45 10/100 Mbps port. The bottom IMM card is connected to Device A through its RJ-45 10/100 Mbps port and to Device C through its 1000Mbps GBIC Receive port.

If an IMM card in an OPV-LA is connected to both a 10/100 Mbps device and a 1000Mbps device, only one link can be active at a time. In the example, the user selects either the half-duplex 10/100 Mbps link to Device A or the link to the 1000 Mbps mirror port at Device C.

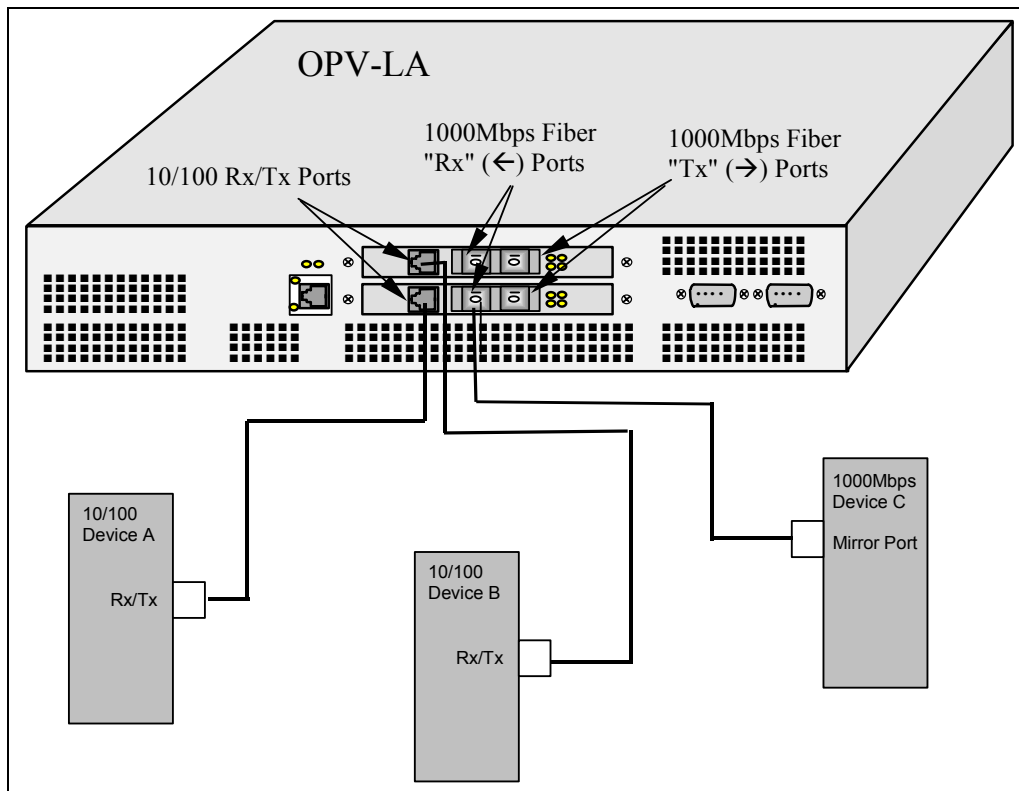

Figure 3. OPV-LA System Half-Duplex and Single Mirror Port Connections

Connecting to Multiple Segments through a 12-Port Tap

The OptiView™ Link Analyzer can be rack-mounted in a wiring closet and attached to a 12-Port Tap to monitor up to 12 half or full-duplex 10/100 Mbps Ethernet segments.

The port pairs 1 through 12 on the Tap-12 are connected to different LAN segments. The OPV-LA is connected to the Tap-12 using ports A and B for LAN analysis and monitoring functions. A connection is also made between the 9-pin Tap port on the OPV-LA and the 9-pin port on the Tap-12. See Figure 4.

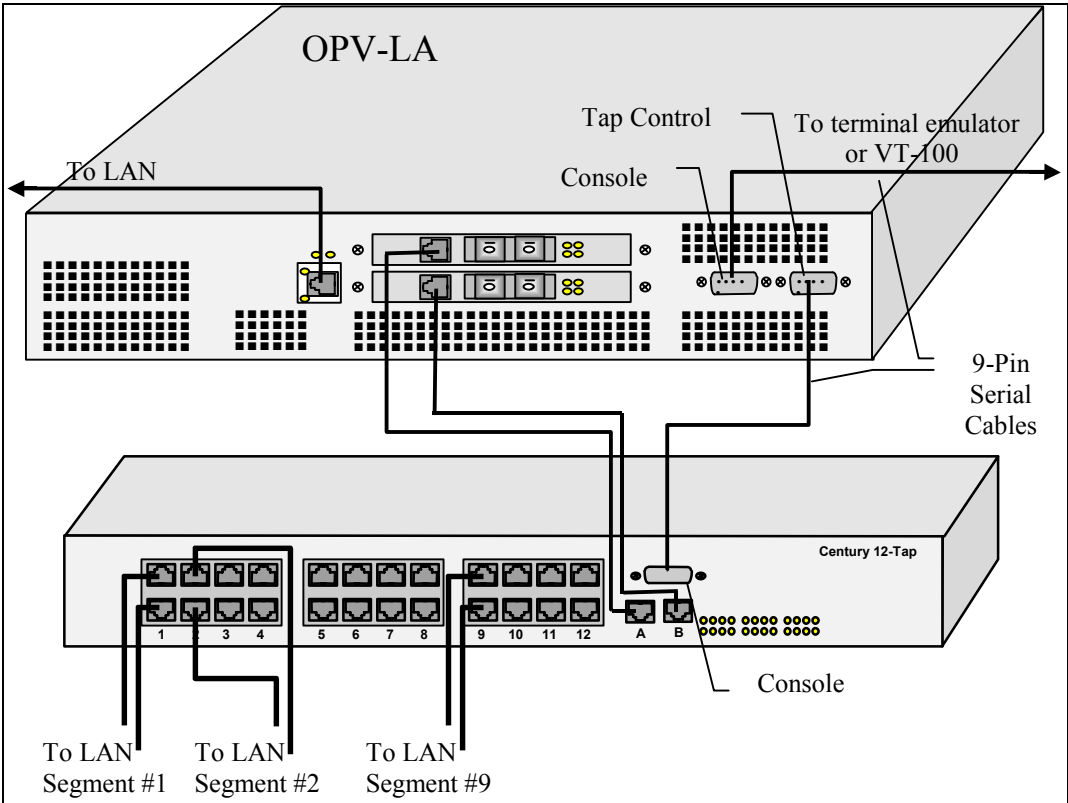

Figure 4. OPV-LA to Tap-12 Configuration

Connecting the OPV-LA in this way allows you to view and manage both the OPV-LA and the Tap-12 when you are using the OptiView™ Protocol Expert software. You can select one of the 12 possible segments to analyze. The selected segment is mirrored to the Tap-12's Tap A and Tap B ports which are connected to the OPV-LA analyzer ports. This communication occurs through the serial port

connection between the Tap-12 and the OptiView™ Link Analyzer. The OptiView™ Protocol Expert software also enables you to use the OPV-LA as both a troubleshooting and monitoring system.

Note

All serial cable connections to the OPV-LA are straight-through connections:

- *PC Console-to- OPV-LA Console port*
- *OPV-LA Tap port-to-Tap-12*

The connection between the OptiView™ Link Analyzer and the PC or VT-100 is only required during the OPV-LA setup and is not required for operation of the Link Analyzer.

Connecting to a 1000Mbps Link through a Fiber Tap

The OptiView™ Link Analyzer can be rack mounted in a wiring closet and attached to a Fiber Tap to monitor a single full-duplex gigabit Ethernet link.

The OPV-LA is connected to the Fiber Tap using tap ports A and B. For passive monitoring in both directions of a full duplex link, connect the "Rx" (←) ports on the two IMM modules to the tap ports. The data to the receive port of each device (Switch A and Switch B) is mirrored to the Tap A and Tap B ports.

Note that the connections to the Fiber Tap from the switches use straight-through cables. The connections are made directly from the "Rx" port on the Switch to the "Out" port on the Fiber Tap and the "Tx" port on the Switch to the "In" port on the Fiber Tap. Refer to the following figure.

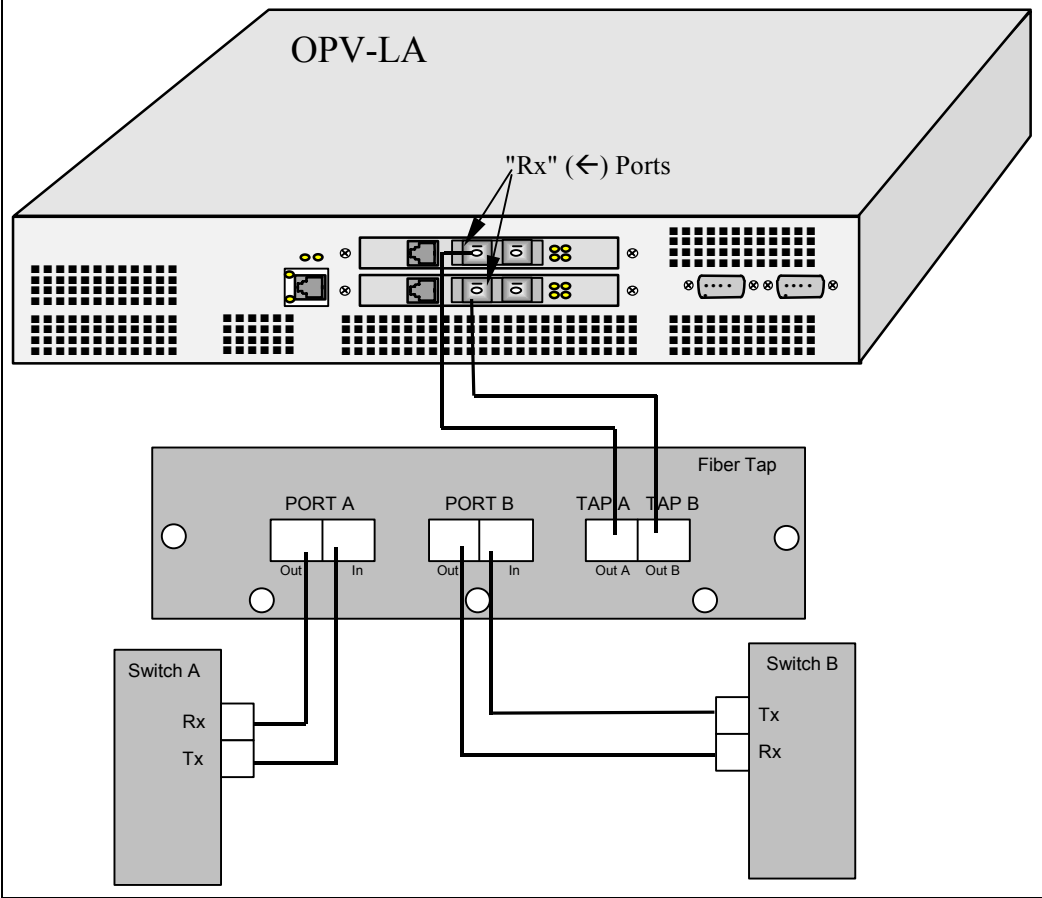

Figure 5. OPV-LA to Fiber Tap Configuration

Connecting to Multiple 1000Mbps Segments through a Multi-Port Tap or Access Switch

The OptiView™ Link Analyzer can be attached to a multi-port tap or switch to monitor 1000Mbps Ethernet segments.

The port pairs on the switch are connected to different LAN segments. The OptiView™ Link Analyzer is connected to the switch tap ports from its 1000Mbps receive ports for LAN analysis and monitoring functions.

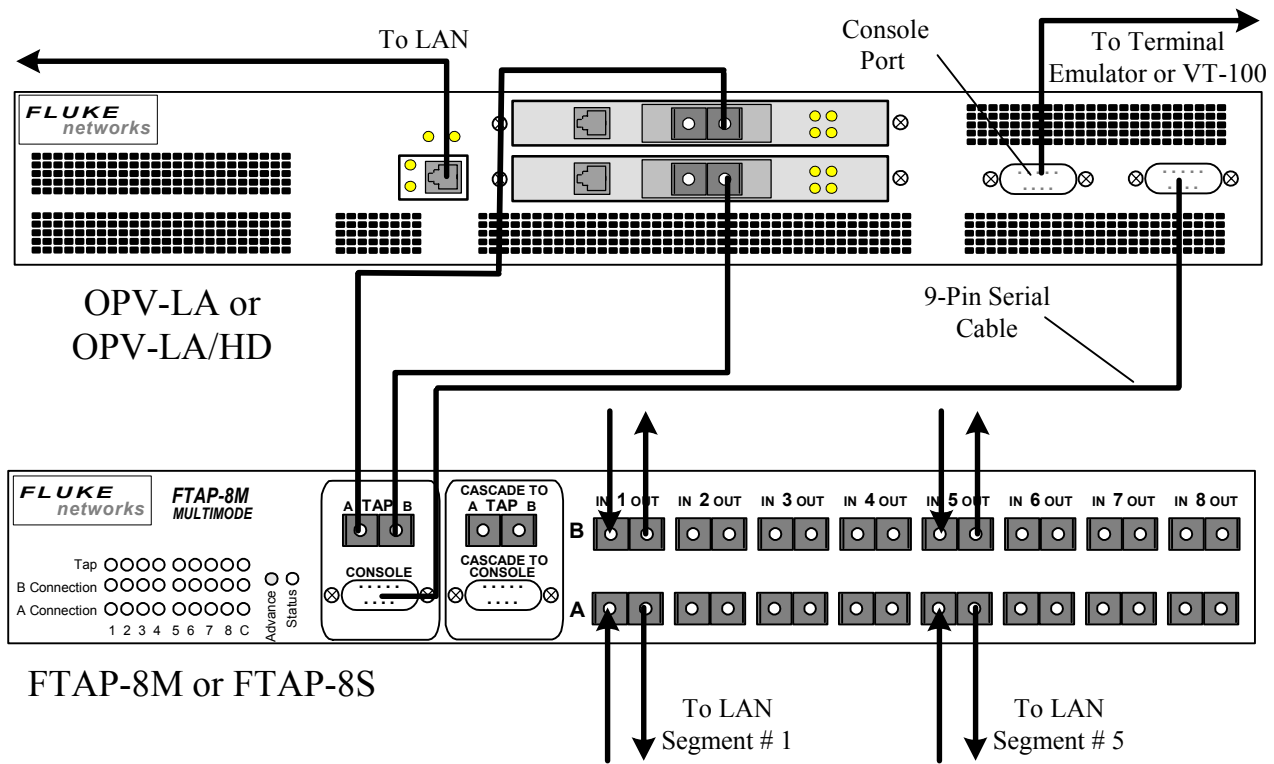

Figure 6. OPV-LA System to FTAP-8M or FTAP-8S Multi-Port Tap Configuration

Connecting OptiView™ Link Analyzer via a Fluke Networks FTAP-8M or FTAP-8S multi-port tap allows you to view and manage both the OPV-LA and the switch from within the OptiView™ Protocol Expert software. You can select any of the segments to analyze connected to the switch. The selected segment is mirrored to the tap ports which are connected to the OPV-LA analyzer ports. This communication occurs through the serial port connection between the multi-port tap and the OPV-LA. The OptiView™ Protocol Expert software enables you to use the OPV-LA as both a troubleshooting and monitoring system.

NOTE:

All serial cable connections to OPV-LA are straight-through connections:

PC 9-pin Serial port to OPV-LA console port

OPV-LA Tap Control port to multi-port fiber switch console port

The connection between the OPV-LA and the PC or VT-100 is only required during OPV-LA set up and is not required for operation.

All Fluke Networks multi-port taps or switches are supported from OPV-PE.

OPV-LA System Operation Commands

The OptiView™ Link Analyzer user interface for system operation consists of a single command and several options you can set or get for the module. These commands correspond to operations that can also be performed from the OptiView™ Protocol Expert software. Table 2 lists all OptiView™ Link Analyzer operation commands.

All commands specify a module number. Module 2 corresponds to the top card in the OPV-LA chassis, Module 1 corresponds to the bottom card in the OPV-LA chassis. Module 3 corresponds to the two cards in the OptiView™ Link Analyzer when synchronized for full-duplex operation.

Table 2. OPV-LA System Operation Commands

OPV-LA Command	Command Description
<code>module captureSlice</code>	Set the module capture slice value
<code>module currentSettings</code>	Get the module current settings
<code>module direction</code>	Set the module direction to transmit or receive
<code>module getSpeed</code>	Get the module speed
<code>module monitorSlice</code>	Set the module monitor slice value
<code>module rxCounters</code>	Get the values for frame and byte receive counters
<code>module rxOption</code>	Set the option for receiving data to capture, monitor, or both
<code>module setInterface</code>	Enable/disable RJ45 interface
<code>module startRx</code>	Start a module for receiving data.
<code>module stopRx</code>	Stop a module when receiving data.

module captureSlice

Syntax: `module captureSlice <moduleNumber>`
 `<64 | 128 | All>`

Description: Use this command to set the capture packet slicing size for the specified module. A value of `All` selects the entire packet for capture.

Examples: `module captureSlice 1 128`

module currentSettings

Syntax: module currentSettings <moduleNumber>

Output: Module x Current settings:
 Interface: [RJ45 | GBIC]
 Speed: [10 MBPS | 100 MBPS | 1 GBPS]
 Arm status: [armed | disarmed]
 RX option: [Capture | Monitor | Capture and
 Monitor]
 Direction: [Receiving | Transmitting]
 Capture Slice: [64 | 128 | all bytes]
 Monitor Slice: [64 | 128 | all bytes]

Description: Use this command to get the interface, speed, arm status, receive
 mode, direction, and packet slicing size for a module.

Example: module currentSettings 1
 Interface: RJ45
 Speed: 100 MBPS
 Arm status: armed
 RX option: Capture and Monitor
 Direction: Receiving
 Capture Slice: all bytes
 Monitor Slice: all bytes

module direction

- Syntax: `module direction <moduleNumber>`
`[Rx | Tx | Both]`
- Description: Use this command to set the direction of the module to receive, transmit, or both. The command returns an error message if the module is armed (actively receiving or transmitting data) or locked. The module can only be locked from OPV-PE software. If the `RxOption` variable is used to change the receive option, the direction is reset to Rx.
- Examples: `module direction 2 Rx`
`module direction 1 Tx`
- `module startrx 2`
`module direction 2 Tx`
Error direction: Module 2 is already armed

module getSpeed

- Syntax: `module getSpeed <moduleNumber>`
- Output: `Module speed: [10 MBPS | 100 MBPS | 1 GBPS`
`| NO LINK]`
- Description: Use this command to get the module speed. The command returns 10 MBPS, 100 MBPS, or 1 GBPS. The command returns NO LINK if no link is currently established with the module.
- Examples: `module getspeed 1`
Module speed: 100 MBPS

module monitorSlice

- Syntax: `module monitorSlice <moduleNumber>`
`<64|128|All>`
- Description: Use this command to set the monitor packet slicing size for the specified module. A value of All selects the entire packet for monitor.
- Examples: `module monitorSlice 1 128`

module rxCounters

Syntax: `module rxCounters <moduleNumber>`

Output: `Frames Captured: xxx`
`Bytes Captured: xxx`

where `xxx` is the counter value.

Description: Use this command to get the current receive counters for all frames and all bytes captured.

Examples: `module rxCounters 1`
`Frames Captured: 244,556`
`Bytes Captured: 38,124,334`

module rxOption

Syntax: `module rxOption <moduleNumber>`
`[CAPTURE | MONITOR | CAP-MON | CAP-DISK]`

Description: Use this command to set the capture/monitor mode of the module. If the module is unarmed and in transmit mode, the mode is reset to the specified receive option. The command returns an error message if the module is armed (actively receiving or transmitting data) or locked. The module can only be locked from Protocol Inspector software.

The CAP-DISK mode only applies to OPV-LA/HD models equipped with an internal disk. The CAP-DISK mode streams the capture continuously to disk. The command returns an error message if you attempt to set this mode on a OPV-LA.

Examples: `module rxoption 2 capture`
`module rxoption 1 monitor`

`module startrx 2`
`module rxoption 2 monitor`
`Error SetRx: Module 2 is already armed`

module setInterface

- Syntax: `module setInterface <moduleNumber> [RJ45 | GBIC]`
- Description: Use this command to select the interface. When set to RJ45, the module uses the 10/100 Mbps RJ45 port. When set to GBIC, the module uses the 1000Mbps GBIC fiber ports.
- Examples: `module setInterface 2 GBIC`

module startRx

- Syntax: `module startRx <moduleNumber>`
- Description: Use this command to start capture/monitor operations for the module. If the module is set to transmit mode or is already armed, the command returns an error.
- Examples: `module startRx 3`
- `module startRx 3`
`Error DoRx: Module 3 already armed`

module stopRx

- Syntax: `module stopRx <moduleNumber>`
- Description: Use this command to stop capture/monitor operations for the module. If the module is already stopped, the command returns an error.
- Examples: `module stopRx 3`
- `module stopRx 3`
`Error StopRx: Module 3 already stopped`

OPV-LA Setup Commands

The OptiView™ Link Analyzer user interface consists of 6 commands: *Get*, *Set*, *Del*, *Clear*, *Ping*, and *Help*. Table 3 on the following page lists all the variables and shows which commands are available for each variable. The *Help* command is available for all variables.

Commands are used to set up the device, obtain information about the current hardware and software, and perform software updates. The OPV-LA LAN analysis and monitoring functions are controlled using the OptiView™ Protocol Expert software.

Set, Get, and Del Commands

Set – sets the value of a variable.

Get – gets the value of a variable.

Clear – restores default values.

Del – deletes an element in variable.

The general form for the *set* command is:

```
set <variable> <new-setting>
```

where *<variable>* is the command variable and *<new-setting>* is the new value assigned to the variable or a new entry in a table.

The general form for the *get* and the *clear* commands are as follows:

```
get <variable>  
clear <variable>
```

where *<variable>* is the OPV-LA command variable.

The general form for the *del* command is:

```
del <variable> <table-element>
```

where *<variable>* is the command variable and *<table-element>* is an element in a table.

An error message is returned if incorrect syntax is used.

Ping Command

The ping command uses an IP address as its command line parameter.

The general form for ping commands is as follows:

```
ping [<IPaddress>]
```

where <IPaddress> is the IP address of a remote host. If no IP address is specified, the OptiView™ Link Analyzer will ping the local server.

Using Help

To get help for any variable, type help and the variable name at the command line. The general form for the help command is:

```
help <variable>
```

<variable> is the command variable.

For example, type:

```
help ipaddr
```

The OPV-LA returns the following:

```
Use this command to set/get the systems IP Address  
in dotted notation.
```

Use the help command without any variables to get a list of all variables available.

Setting the System Time and Date

It is recommended that when setting up the OptiView™ Link Analyzer for the first time that you set the date, time, and ntpMinFromUTC variables and restart the system. These variables allow the OPV-LA to accurately compute timestamps.

The OptiView™ Link Analyzer does not make local time changes, such as daylight savings time. Use the ntpMinFromUTC variable to reflect local time changes in timestamps. After setting the ntpMinFromUTC variable, it is advisable to update the system clock.

Note that there are two ways to update the system time. Use the ntpUpdate and ntpUpdateInterval variables to update the time if you are using an NTP server. Use the date and time variables if you are not using an NTP server.

OPV-LA Setup Commands

Table 3. User Interface Commands and Variables

Command Variables	Variable Description	OPV-LA Commands			
		Get	Set	Del	Clear
connectingClients	Get list of all connected clients	❖			
date	System date	❖	❖		
disconnectClient	Disconnect all or selected clients		❖		
email	E-mail settings for the OPV-LA	❖	❖	❖	
imageProperties	Time of last software update	❖			
ipAddr	IP address of the OPV-LA	❖	❖		❖
ipDefGw	Gateway IP Address to server	❖	❖		❖
ipServerAddr	Server IP Address	❖	❖		❖
ipSettings	All IP address settings	❖			❖
ipSubnetMask	The OPV-LA subnet mask	❖	❖		❖
ldBootFile	Path/filename of remote OPV-LA image for update	❖	❖		
ldBootMode	Mode for loading boot information, network or local	❖	❖		
ldLoadMode	Mode for loading OPV-LA software, network or local	❖	❖		
ntpAutoUpdate	Enable/disable auto-updating system clock using NTP	❖	❖		
ntpMinFromUTC	Difference between local time and UTC	❖	❖		
ntpServerAddress	Address of the NTP server	❖	❖		
ntpSettings	Display all NTP variable values	❖			
ntpTimeoutValue	How long OPV-LA will wait for the NTP server's response	❖	❖		
ntpUpdate	Update system clock using NTP		❖		
ntpUpdateInterval	Interval for auto-updating the system clock using NTP	❖	❖		
snmpComm	SNMP communications	❖	❖	❖	

OptiView™ Link Analyzer
Users Manual

Command Variables	Variable Description	OPV-LA Commands			
sysBootSwVersion	Boot software version	❖			
sysHwBoardId	OPV-LA model and serial number	❖			
sysHwMacAddr	MAC address of OPV-LA management port	❖			
sysHwReset	Reset OPV-LA		❖		
sysHwVersion	OPV-LA hardware version	❖			
sysMgmtPortSpeed	OPV-LA RJ45 management port speed	❖	❖		
sysResetType	Reset type of last reset	❖			
sysSwVersion	OPV-LA software version	❖			
systemInfo	Get all system properties	❖			
sysUpTime	Time since last reset	❖			
tapRescan	Rescan for tap devices		❖		
telAccess	Enable/disable Telnet access	❖	❖		
telTimeout	Telnet time out value	❖	❖		
time	System time	❖	❖		
usrTable	User table for remote access	❖	❖	❖	
wdTimer	Enable/disable watchdog timer	❖	❖		

OPV-LA Setup Command Variables

This section contains detailed descriptions of the OptiView™ Link Analyzer command variables. Commands and variables are not case sensitive.

connectingClients

Syntax: `get connectingClients`

Output: The clients connecting to this server:
`x.x.x.x`
`x.x.x.x`
`x.x.x.x` represents an IP address in IP dot notation.

Description: Use this variable to get the list of clients currently connecting to this OPV-LA device.

Example: `get connectingClients`
The clients connecting to this server:
`192.168.2.214`
`192.168.1.172`

date

Syntax: `set date mm dd yyyy`
`get date`

Output for Get: `Current date is mmm dd, yyyy`

Description: Use this variable to set/get the OPV-LA system date.

Examples: `set date 08 01 2000`
`get date`
`Current date is Aug 01, 2000`

disconnectClient

Syntax: `set disconnectClient [ALL|<ipAddr>]`

Output: `Disconnect client x.x.x.x`
`Disconnect client x.x.x.x`
`x.x.x.x` represents an IP address in IP dot notation.

Description: Use this variable to disconnect a client or all clients from the OPV-LA.

Example: `set disconnectClient all`
`Disconnect client 192.168.2.214`
`Disconnect client 192.168.1.172`

email

Syntax: set email to <addr1> [<addr2>..]
 set email smtp <domain_name> <server_ip_addr>
 set email sender <addr>
 get email
 del email to <addr1> [<addr2> ...]

Output for Get: The recipients list is a list of all e-mail addresses that have been established for the OPV-LA.

```
Recipients:  <e-mail address1>
              . . .
              <e-mail addressn>
Domain name: <e-mail address>
SMTP server: <ip-address>
Sender:      <e-mail address>
```

Description: Use this variable to get/set/delete email settings for the OPV-LA. You can perform the following operations:

- add recipients to the email account
- delete recipients from the email account
- set the smtp domain name and IP address
- set the sender IP address (e-mail address of the OPV-LA)
- get the current email account settings

Examples: set email to somebody@customersite.com
 another@customersite.com
 unlucky@customersite.com
 set email smtp mail.customersite.com
 192.168.2.1
 set email sender OPV-LA@customersite.com
 del email to unlucky@customersite.com
 get email
 Output:
 Recipients: somebody@customersite.com
 another@customersite.com
 Domain name: mail.customersite.com
 SMTP server: 192.168.2.1
 Sender: OPV-LA@customersite.com

imageProperties

Syntax: `get imageProperties`

Output for Get: File name, last update, and file size for the system image followed by the file name, last update, and file size for the boot image.

Description: Use this variable to get the file name, file size, and the date of the last time that the software and boot images were updated for the OPV-LA. The name for each file is sequenced so you can tell which version of software is installed for the OPV-LA.

Examples: `get imageproperties`

```
File: dp20b057.img
Last updated: TUE NOV 07 11:43:00 2000
Size: 2792448 (bytes)

File: bootrom.img
Last updated: TUE JAN 01 00:00:00 1999
Size: 194560 (bytes)
```

ipAddr

Syntax: `set ipAddr a.b.c.d`
`get ipAddr`

Output for Get: `a.b.c.d`

a, b, c, and d are whole numbers in the range of 0 to 255.

Description: Use this variable to set/get the OPV-LA IP Address in dotted notation.

Examples: `set ipAddr 207.135.68.74`

```
get ipAddr
207.135.68.74
```

ipDefGw

Syntax: `set ipDefGw a.b.c.d`
`get ipDefGw`

Output for Get: `a.b.c.d`

a, b, c, and d are whole numbers in the range of 0 to 255.

Description: Use this variable to set/get the default gateway IP Address in dotted notation. The gateway IP address is typically the address of the router through which you reach the server.

Examples: `set ipDefGw 207.135.68.0`

```
get ipDefGw
207.135.68.0
```

ipServerAddr

Syntax: set ipServerAddr a.b.c.d
 get ipServerAddr

Output for Get: a.b.c.d

a, b, c, and d are whole numbers in the range of 0 to 255.

Description: Use this variable to set/get the BOOTP/TFTP server IP Address in dotted notation.

Examples: set ipServerAddr 207.135.124.75
 get ipServerAddr
 207.135.124.75

ipSettings

Syntax: get ipSettings
 clear ipSettings

Output for Get: a.b.c.d

a, b, c, and d are whole numbers in the range of 0 to 255.

Description: Use this variable to get/clear the current IP settings for the OPV-LA, including the OPV-LA IP Address, the default gateway IP Address, and the BOOTP/TFTP server IP Address, and the OPV-LA subnet mask.

Examples: clear ipsettings
 get ipsettings
 Output:: ipAddr = 207.135.68.74
 Output:: ipSubnetMask = 255.255.255.0
 Output:: ipDefGw = 207.135.68.1
 Output:: ipServerAddr = 207.135.68.104

ipSubnetMask

Syntax: set ipSubnetMask a.b.c.d
 get ipSubnetMask

Output for Get: a.b.c.d

a, b, c, and d are whole numbers in the range of 0 to 255.

Description: Use this variable to set/get the OPV-LA subnet mask in dotted notation.

Examples: set ipSubnetMask 255.255.255.0
 get ipSubnetMask
 225.255.255.0

ldBootFile

Syntax: set ldBootFile {path/filename}
 get ldBootFile

{path/filename} is an ASCII string.

Output for Get: an ASCII string

Description: Use this command to set/get the image file to be downloaded. This includes the TFTP directory and file name. The address of the server containing the boot file is set using the ipServerAddr variable.

The image file specified by this variable will be loaded to the OPV-LA when the load mode is set to `Network` and the OPV-LA is reset. The image file is copied from the server and stored in local non-volatile memory. Subsequent restarts of the OPV-LA will use the new local image. The image on the server is not recopied to the OPV-LA unless another `set ldLoadMode Network` command is issued followed by a reset.

Example: set ldBootFile c:\tftp\dp20b057.img
 get ldBootFile
 c:\tftp\dp20b057.img

Note that the example is for a PC TFTP server. A Unix TFTP server path uses forward slashes.

Caution

Losing power during the boot image file upgrade procedure will cause the OPV-LA module to permanently fail to boot. The unit will not be damaged but must be returned to Fluke Networks for reprogramming.

ldBootMode

Syntax: `set ldBootMode [Local | Network]`
 `get ldBootMode`

Output for Get: `Local` or `Network`

Description: Use this variable to set/get the configuration (boot) mode to `Local` or `Network`.

`Local` use current configuration stored in non-volatile memory.

`Network` download configuration parameters, using BOOTP, and update configuration information in non-volatile memory.

The configuration parameters consist of address information for the OPV-LA and address information for the Server, the Gateway, and the Subnet mask. If the boot mode is set to `Network`, address information is downloaded from the network.

The following configuration parameters are updated:

```
ipAddr  
ipDefGw  
ipServerAddr  
ipSubnetMask  
ldBootFile
```

Once a boot is performed and address information is updated, the boot mode is always reset to `Local`.

Examples: `set ldBootMode network`

```
get ldBootMode  
Network
```

ldLoadMode

Syntax: `set ldLoadMode [Local | Network]`
 `get ldLoadMode`

Output for Get: `Local` or `Network`

Description: Use this variable to set/get the image load mode to `Local` or `Network`.

`Local` use local image resident in FLASH memory.

`Network` download image from TFTP server, update FLASH memory, and execute this image.

When you set the load image mode to `Network`, the OPV-LA will attempt to download a software image from the network, using the Server address, Gateway address, and Subnet mask set for the system. The download is attempted the next time the system is restarted. You can restart the OptiView™ Link Analyzer by using the `set sysHwReset warm` command. The file to load is specified by the `ldBootFile` variable. If the load fails, an error message appears.

Once a load is performed, the load mode is always reset to `Local`.

Examples: `set ldLoadMode network`
 `get ldLoadMode`
 `Network`

ntpAutoUpdate

Syntax: `set ntpAutoUpdate [ON | OFF]`
 `get ntpAutoUpdate`

Output for Get: `ntpAutoUpdate = [ON | OFF]`

Description: Use this variable to set/get the OPV-LA to automatically update its system clock from the NTP server.

The default is `OFF`. If you attempt to change the `autoUpdate` value to its current value, the OPV-LA returns an error message.

Examples: `set ntpAutoUpdate on`
 `get ntpAutoUpdate`
 `ntpAutoUpdate = on`

ntpMinFromUTC

Syntax: set ntpMinFromUTC <minutes>
 get ntpMinFromUTC

Output for Get: ntpMinFromUTC = <minutes>

Description: Use this variable to set/get the difference between local and UTC
(Universal Time).

The system does not automatically support Daylight Savings Time. For local time changes, the ntpMinFromUTC value should be adjusted manually according to the local time.

The default value is 420.

Examples: set ntpMinFromUTC 390
 get ntpMinFromUTC
 ntpMinFromUTC = 390

ntpServerAddr

Syntax: set ntpServerAddr [a.b.c.d | <servername>]
 get ntpServerAddr

Output for Get: a.b.c.d

a, b, c, and d are whole numbers in the range of 0 to 255.

Description: Use this variable to set/get the NTP server address. When specifying a server name for the set command, the length of the server name must be less than 40 characters. The get command always returns the server address in IP dotted notation.

The default server address is 207.0.72.4.

If you attempt to set the variable to a name 40 characters or greater, the OPV-LA returns an error message.

Examples: set ntpServerAddr 207.135.68.74
 get ntpServerAddr
 ntpServerAddr = 207.135.68.74

ntpSettings

Syntax: get ntpSettings

Output for Get: List of all NTP settings

Description: Use this variable to get the current settings for the NTP variables on the OPV-LA. The values in the example below are the default values.

Example: get ntpSettings
 ntpServerAddr = 207.0.72.4
 ntpTimeoutValue = 10 (secs)
 ntpMinFromUTC = 420 (mins)
 ntpAutoUpdate = off
 ntpUpdateInterval = 60 (mins)

ntpTimeoutValue

Syntax: set ntpTimeoutValue <integer-number>
 get ntpTimeoutValue

Output for Get: ntpTimeoutValue = <integer-number>

Description: Use this variable to set/get the time to wait before disconnecting an inactive NTP server communication session with the OPV-LA. The time out value is in seconds.

The default time out value is 10 seconds.

A value of zero is not allowed. If you attempt to change ntpTimeoutValue to a value less than or equal to zero, OPV-LA returns an error message.

Examples: set ntpTimeoutValue 15
 get ntpTimeValue
 ntpTimeoutValue = 15

ntpUpdate

Syntax: set ntpUpdate

Description: Use this variable to update the OPV-LA system clock from the NTP server.

The OPV-LA returns the current system clock information.

Example: set ntUpdate
 Updating system clock
 Current date is Nov 15, 2000
 Current time is 17:8:30

ntpUpdateInterval

Syntax: `set ntpUpdateInterval <minutes>`
 `get ntpUpdateInterval`

Output for Get: `ntpUpdateInterval = <minutes>`

Description: Use this variable to set/get the interval for auto-updating the OPV-LA system clock from the NTP server. If the `ntpAutoUpdate` variable is set to `OFF`, the value of this variable is ignored.

The default interval is 60 minutes. If the value for `minutes` used in the `set` command is less than or equal to zero, the OPV-LA returns an error message.

Examples: `set ntpUpdateInterval 80`
 `get ntpUpdateInterval`
 `ntpUpdateInterval = 80`

snmpComm

Syntax: `set snmpComm community [r] [w] [t] [ipAddress]`
 `get snmpComm`
 `del snmpComm community [r] [w] [t] [ipAddress]`

Output for Get: List of current communities, associated privileges, and IP addresses

Description: Use this variable to set/get/delete entries in a table that is used when logging on to the OPV-LA from remote PCs running the OptiView™ Protocol Expert software through SNMP. Traps can also be set for OPV-LA events.

The parameters for this variable are:

`community` An ASCII string representing the community string. The community string is the name associated with the OPV-LA and a set of SNMP managers allowed to manage the OPV-LA with the specified privilege level.

`r/w` Sets the type and access privileges for the community string. Possible types are:

`r` gives the community privileges to read the OPV-LA status.

`rw` gives the community privileges to change the OPV-LA status as well as read status.

`t` Sets a trap for the community. A Trap will cause a message to be sent to a specified `ipAddress` when certain events occur at the OPV-LA device.

`ipAddress` Sets an IP address to send a trap to for this community.

The OptiView™ Link Analyzer supports traps as defined in RFC 1215. A message to the trap address or addresses is generated when the following OPV-LA system events occur:

- warmStart
- coldStart
- authenticationFailure

Messages to the trap addresses are also generated when the following events occur at the OPV-LA management or analyzer ports:

- linkUp (management or analyzer ports)
- linkDown (analyzer ports only)

Multiple IP addresses may be set for each trap; however, you must issue a new command to set each new IP address. Deleting a trap without an IP address specified deletes all the IP addresses for the trap within the community.

A maximum of 15 communities are supported.

The OptiView™ Link Analyzer incorporates MIB II (RFC 1213) system group members. The system group members sysContact, sysName, and sysLocation are stored in non-volatile memory at the OPV-LA. These values can only be changed through an SNMP manager.

MIB II interface groups are supported on all interfaces. However, only the management port has a dedicated MAC address / IP address. No other port can be used as a management interface. IP groups / TCP groups are only valid for the management port.

There are two default community strings:

- public Community for read-only SNMP operations.
- private Community for read-write SNMP operations.

```
Examples:  set snmpComm foo rwt 207.135.68.16
           set snmpComm manager t 207.135.68.14

           get snmpComm
           public  r
           private r w
           foo    r w t      207.135.68.16
           manager t        207.135.68.14

           del snmpComm foo rwt
           del snmpComm manager t 207.135.68.14
```

sysBootSwVersion

Syntax: get sysBootSwVersion

Output: an ASCII string

Description: This variable displays the Software Version of the Boot Image.
 The Software version is defined as Major release number, Minor release number, and Build number. The software version cannot be set.

Example: get sysBootSwVersion
 V1.0.Build 101

sysHwBoardId

Syntax: `get sysHwBoardId`

Output: an ASCII string

Description: This variable contains the hardware board ID. The board ID contains a Model Number and a Serial Number. The hardware board ID cannot be set.

Example: `get sysHwBoardId`
Model Number: 1005 Serial Number: 4023

sysHwMacAddr

Syntax: `get sysHwMacAddr`

Output: `sysHwMacAddr = {macAddr}`
MacAddr is a 6-byte MAC Address

Description: Use this command to display the MAC Address of the OPV-LA management port. The output will be in hexadecimal.
The management port MAC address of the OPV-LA cannot be set.

Example: `get sysHwMacAddr`
`sysHwMacAddr = 00:60:e6:00:01:03`

sysHwReset

Syntax: `set sysHwReset {Warm, Cold, Factory}`

Description: Use this command to reset the OPV-LA. There are three types of resets:

- Warm Reset the board without doing power on self-tests.
- Cold Reset the board doing power on self-tests.
- Factory Reset the board to the factory default configuration. A cold start reset will follow.

`sysHwReset` cannot be used with the `get` command.

Example: `set sysHwReset warm`

sysHwVersion

Syntax: `get sysHwVersion`

Output: an ASCII string

Description: This variable contains the Hardware Version. The hardware version is defined by a major release number and a minor release number. The hardware version cannot be set.

Example: `get sysHwVersion`
Hardware Revision Number: 1.1

sysMgmtPortSpeed

Syntax: `set sysMgmtPortSpeed {10, 100, auto}`
`get sysMgmtPortSpeed`

Output for Get: `10, 100, sysMgmtPortSpeed = auto`

Description: Use this variable to set/get the speed of the OPV/LA RJ45 management port. The Management Port will auto-negotiate the speed if the speed is set to auto. The default setting is auto.

Examples: `get sysmgmtportspeed`
`sysMgmtPortSpeed = auto`
`set sysmgmtportspeed 100`
`get sysmgmtportspeed`
`100`

sysResetType

Syntax: `get sysResetType`

Output: `Warm, Cold`

Description: Use this command to get the type of the last OPV-LA system reset. `sysResetType` cannot be set.

Example: `get sysResetType`
`Warm`

sysSwVersion

Syntax: `get sysSwVersion`

Output: an ASCII string

Description: This variable contains the Software Version of the System Image. The Software version is defined as Major release number, Minor release number, and Build number. The software version cannot be set.

Example: `get sysSwVersion`
`V1.0.Build 201`

systemInfo

Syntax: get systemInfo

Output: (see below)

Description: Use this command to get OPV-LA system information. This information also displays on system startup.

Example: get systemInfo

System properties:
=====

Version Information:

H/W Version: OPV-LA	1P	BootImage S/W Version: V2.0 B003
H/W Board Id: 1015000001		S/W Version: V4.0 B020

Host Information:

MAC Address: 00:60:e6:86:18:a2	IP Gateway: 10.10.3.42
IP Address: 10.10.3.10	IP Subnet mask: 255.255.255.0

Modules Information:

Module 1 found @ address 0x101
Module 2 found @ address 0x102
SYNC Module found @ address 0x181

Minutes from UTC: 420

sysUpTime

Syntax: `get sysUpTime`

Output: `nD:nH:nM:nS`
 where { D:H:M:S } represents/ Days/Hours/Minutes/Seconds

Description: This variable displays the length of time since the OPV-LA was last reset.
 The time cannot be set. It will be cleared upon Reset.

Example: `get sysUpTime`
`5D:3H:2M:56S`

tapRescan

Syntax: `set tapRescan`

Output for Get: `Scanning for taps standby...`
`Tap xxx found`
 xxx is the tap model number or tap type.

Description: Use this variable to rescan for any attached taps. You can rescan for newly connected taps without resetting the device. The system prompt and no message are returned if no taps are found.

Examples: `set tapRescan`
`Scanning for taps standby...`
`Tap CT1012-010 Found`

telAccess

Syntax: `set telAccess {Enable,Disable}`
`get telAccess`

Output for Get: `Enable or Disable`

Description: Use this variable to set/get the access mode for Telnet communications.
 Enable Enables the use of Telnet sessions for controlling the OPV-LA.
 Disable Disables the use of Telnet sessions for controlling the OPV-LA.
 The default is Enable.
 Telnet access uses the default destination port, port 23. A maximum of five concurrent Telnet sessions is allowed.

Examples: `set telAccess Enable`
`get telAccess`
`Enable`

telTimeout

Syntax: set telTimeout {0.....60}
 get telTimeout

Output for Get: Whole number in the range 0 to 60

Description: Use this variable to set/get the time to wait (in minutes) before
 disconnecting an inactive Telnet communication session with the
 OPV-LA. A value of zero indicates that no time out will occur.

 The default is 15.

Examples: set telTimeout 30
 get telTimeout
 30

time

Syntax: set time hh mm ss
 get time

Output for Get: Current time is hh:mm:ss

Description: Use this variable to set/get the OPV-LA system time.

Examples: set time 14 30 00
 get time
 Current time is 14:30:03

usrTable

Syntax: set usrTable Username Password Privilege
 get usrTable
 del usrTable Username
 where Username, Password, and Privilege are ASCII strings.

Output for Get: List of current user names and privileges

Description: Use this variable to set/get/delete accounts for logging on to the OptiView™ Link Analyzer from remote PCs running the OptiView™ Protocol Expert software.

- Username An ASCII string representing the user account name.
- Password An ASCII string representing the user account password.
- Privilege One of three ASCII strings that indicate the privileges assigned to this account. The string must be one of the following:
 - super gives the user all privileges. This includes adding users, changing accounts, Telnet access, etc.
 - full gives the user privileges to transmit as well as capture and monitor.
 - capture gives the user capture and monitor privileges.
 - monitor gives the user monitor privileges.

The accounts and privileges are for accessing the OPV-LA using the OptiView™ Protocol Expert software. SNMP access does not use the accounts in the user table.

The OPV-LA has two factory-supplied accounts, as shown in the following table:

Table 4. Default User Names, Passwords, and Privileges

User Name:	Password:	Privileges:
Guest	public	full
Su	manager	super

Examples: set usrTable ann guru super
 del usrTable su
 get usrTable
 Username: Access Level:
 guest full
 ann super

wdtimer

Syntax: `set wdtimer {Enable | Disable}`
 `get wdtimer`

Output for Get: `enable | disable`

Description: Use this variable to enable or disable the OPV-LA watchdog timer. When enabled, the watchdog timer causes a reset signal to be sent to the OPV-LA system if the system is not responding for a period of time. This prevents the user from having to physically locate and cycle the power for a OPV-LA system that has stopped responding.

The watchdog timer is disabled by default.

Examples: `set wdtimer enable`
 `get wdtimer`
 `enable`

OPV-LA and OPV-LA/HD Specifications

Physical Specifications

Height	3.5 in. / 8.9 cm.
Width	14.5 in. / 37 cm.
Depth	13.8 in. / 35 cm.
Weight	18.0 lbs. / 8.2 kg. (22 lbs. shipping weight)
Mount	19.0 in., with rack mount

Environmental Specifications

Temperature	
Operational	0° to 40° C
Non-operational	-10° to 65° C
Humidity	
Operational	10 - 95% non-condensing
Non-operational	10 - 95% non-condensing
Electromagnetic	FCC Class A, CE Compatibility
Safety	UL, CUL, TUV

Power Specifications

Power Consumption	120W
Fuse Protection	2.5A 250V
Input Voltage Range	90-264 VAC
Input Frequency	48-62Hz
Inrush Current (Peak)	40A Maximum

Port Specifications

Analyzer Ports	Gigabit Ethernet: Removable G-BIC, Duplex SC-type connector, Single Mode or Multi-mode 10/100 Mbps Ethernet: RJ-45
Analyzer Port LEDs	Gigabit Link LED, Gigabit software-controlled LED, 10/100 Mbps Link LED, 10/100 Mbps software-controlled LED
Management Port	10/100 Mbps RJ-45
Management Port LEDs	Link Active LED, Speed Indicator LED (10 OFF / 100 ON)
System LEDs	Power, Status
Console Port	9-pin serial port connects to PC
Tap Port	9-pin serial port connects to multi-port tap or switch

Operational Specifications

Data rate	10/100/1000 Mbps
Capture buffer size	128MB
Disk (OPV-LA/HD models only)	80Gbyte IDE
Network compatibility	RJ-45 for 10/100 Mbps Ethernet For Gigabit Ethernet: 1000BASE-SX, Duplex SC connector (Removable G-BIC Connector) 1000BASE-LX, Duplex SC connector (Removable G-BIC Connector)
Standards compliance	IEEE 802.3
Timestamp	25ns resolution

The G-BIC connectors can be purchased separately. A single-mode configuration may be changed to multi-mode by swapping the G-BIC connectors, and vice-versa.